



17,000 DWT / 2x250mt + 1x80mt



BRIESE SCHIFFAHRT

Vessel name	Built	IMO no.	Flag
BBC Nile	03/2011	9571375	Antigua & Barbuda
BBC Ganges	04/2010	9508304	Antigua & Barbuda

Vessel name	Built	IMO no.	Flag
-------------	-------	---------	------

Ship's Basics

Type	Premium Project Carrier Vessel Tweendecker
Builder	Tianjin Xingang Shipyard / China
Classification	GL, 100 A5 ICE E3, G IW, strengthened for Heavy Cargo, equipped for carriage of containers, equipped for the carriage of dangerous goods according to SOLAS II-2, Reg. 19, MC E3 AUT EP-D, CM-PS (not BBC Ganges)

Dimensions & Main Data

Tonnage GT/NT	12,980 / 5,334
Deadweight (summer)	17,000 mt
Length o.a.	143.14 m
Length p.p.	134.43 m
Beam	22.80 m
Max. draft (summer)	9.70 m
Max. speed	15.0 knots
Service speed	14.6 knots
Consumption at sea	30.0 mt fuel per day + 2.2 mt AE
Eco speed	13.0 knots
Consumption eco speed	24.2 mt fuel per day + 2.2 mt AE
Consumption in port	4.7 mt fuel per day (with crane operations) 2.1 mt fuel per day (without crane operations)
Fuel on ME	RMG 380 / RME 180 / MGO DMA / MDO DMB
Fuel on AE	MGO DMA
Tank capacities	RMG 380 / RME 180 abt. 1,458 cbm MGO DMA / MDO DMB abt. 145 cbm Ballast abt. 6,211 cbm Freshwater abt. 259 cbm

Propulsion

Main Engine	MAN B&W 6S46MC-C, 7074 kW
Aux.-Engines	Yanmar, 3 x 660 kW
Propeller	Four bladed fixed pitch propeller

Hold and Hatch

Hold and Hatch	2 Holds / 2 Hatches
Hatch cover type	Folding type
Cargo Hold capacity	19,777 cbm (698,418 cbft)
Floor space under deck	2,986 sqm (32,141 sqft)
Floor space on deck	1,486 sqm (16,002 sqft)
Deck strengths per sqm	20.00 mt on tanktop 4.70 mt on tweendeck 2.20 mt on deck
Tweendeck	Hold 1: 1 height Hold 2: 2 heights
Bulkheads	2 bh / 2 positions

Cargo Gear

Type	2 x 250 mt / 1 x 80 mt NMF
Combinable	500 mt
Situated	Portside

Container Capacity

Capacity	20' or 40' + 20'
Hold	408 / 193 / 22
Deck	550 / 225 / 100
Total	958 / 418 / 122
Reeferplugs	60
Stackload	20' / 40'
Hold	125 mt / 175 mt
Twd	45 mt / 60 mt
Deck	60 mt / 90 mt
Specials	Equipped for 30' container, wide body and high cube container

Special Equipment / Features

IMO classes	Fitted for carriage of dangerous goods of all IMO classes
Other	Fitted for trading Australia Bow thruster

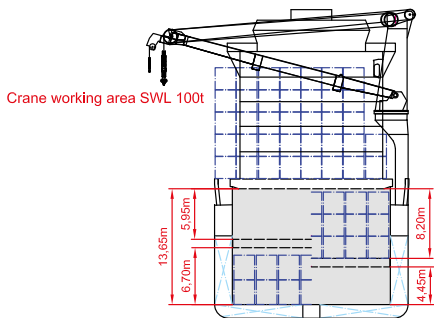

Side View

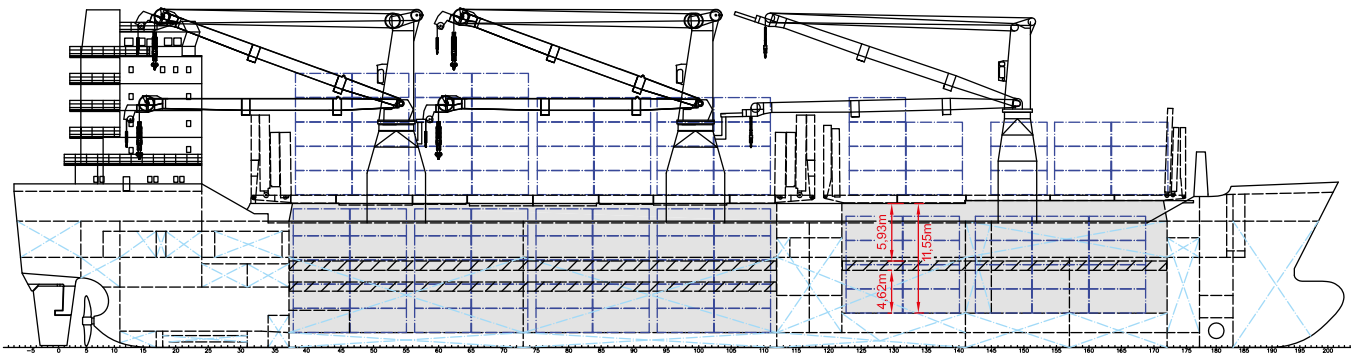

Main Deck

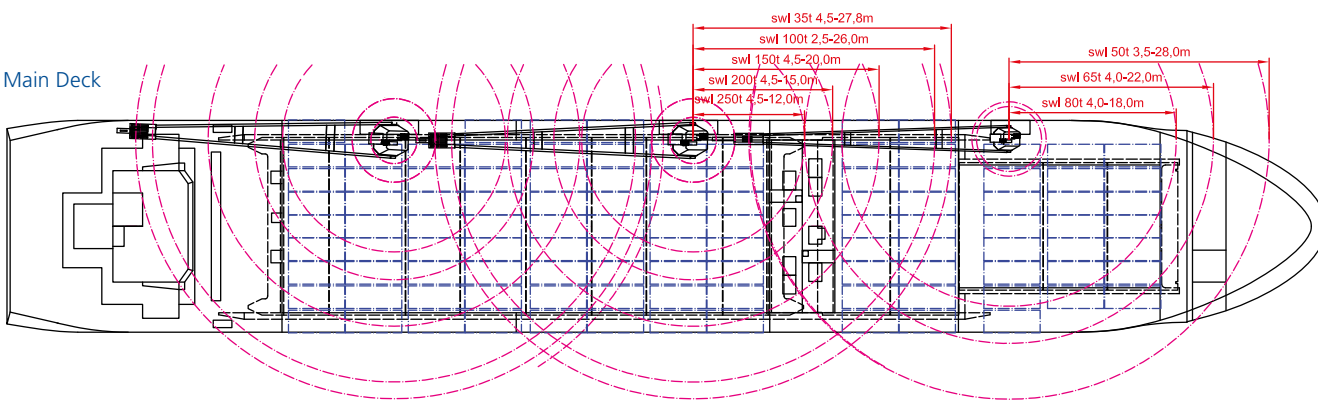

Tweendeck

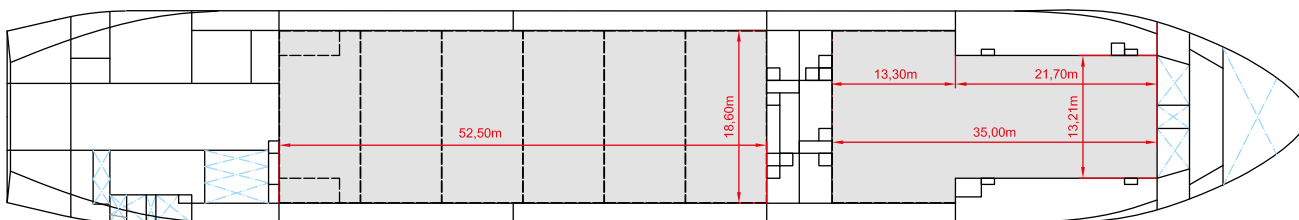

Holds & Double Bottom

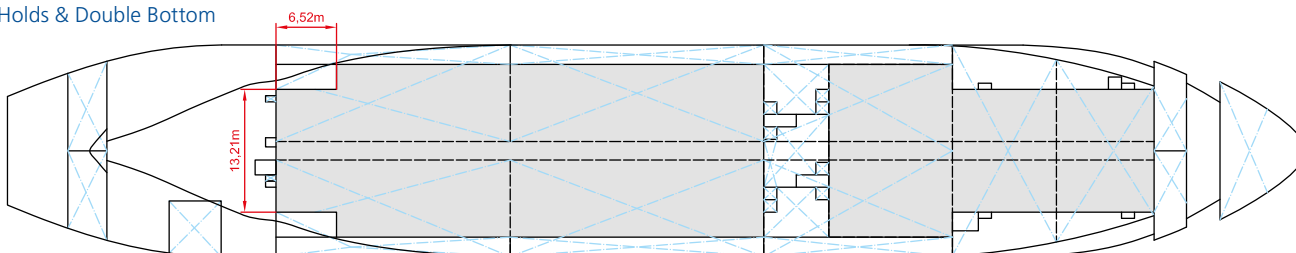

Max. speed is calculated basis 85% MCR, ballast condition, no deck cargo, maximum Beaufort 2, no swell, no adverse currents, clean hull and even keel. Service Speed and consumption at sea is calculated basis 75% MCR, laden condition, no deck cargo, maximum Beaufort 2, no swell, no adverse currents, clean hull and even keel. Eco speed is the minimum continuous speed in laden condition. Consumption data assumes reefer plugs and shaft generator disconnected but including AE if no shaft generator is installed. EEXI and CII related adjustments of speed and consumption are not considered. Vessel is burning fuel according to ISO 8217. Intake is always subject to vessel's stability, trim, permissible weights and is subject to regulations of visibility. Lifting capacity of vessel's cranes is subject to vessel's stability and can depend on cargo/ ballast on board. Container data as well as bale capacity assumes tweendeck ashore. All details including speed and consumption are given in good faith and are "about" and are given without guarantee. They must not be used as basis for charterparties or contracts without owner's explicit written authority.